

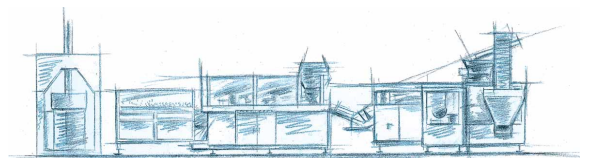

Hydraulic Drum Press FP-1



From the Fischbach machinery line for cartridge filling, accessorizing and case packing.



Fischbach Hydraulic Drum Press FP-1: the reliable supply source for any filling machine.

Features

- Processes flat panel drums and channel drums.
- Reinforced welded frame for evenly and safe extrusion.
- Integrated hydraulic power pack for high feed pressure.
- Three-section steel jacket with safety hook.
- Includes 3 meter supply hose with rapid action hose coupling.
- Superior safety devices in compliance with the European CE Standard.



Three-Section Steel Jacket with Toggle Catch



Double O-Ring with Vent Valve

Technical Data

Type of Machine:	Drum Press FP-1
Max. Feed Pressure:	12 bars
Current:	4 kw
Weight:	1350 kg
Voltage:	230 V/400 V, 50/60 Hz
Control:	PLC

Options

- Pressure plate in stainless steel

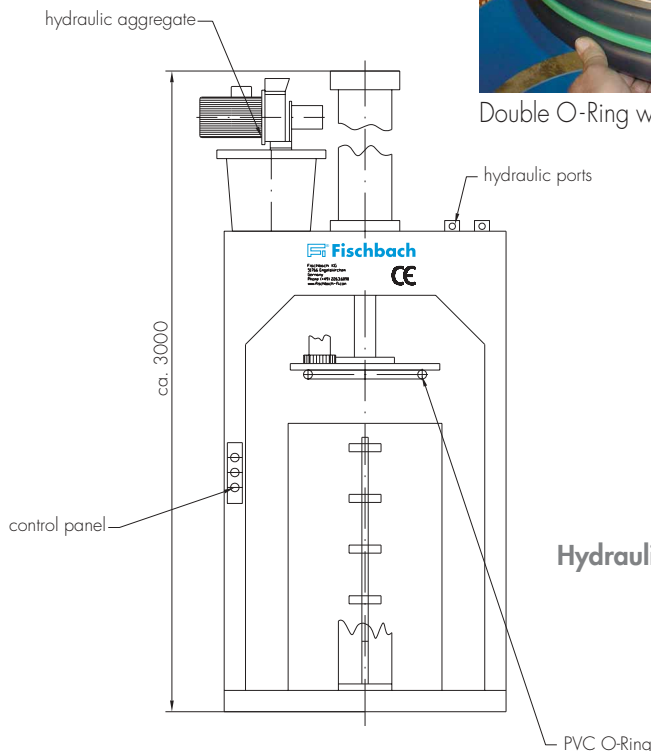

Hydraulic Drum Press FP-1

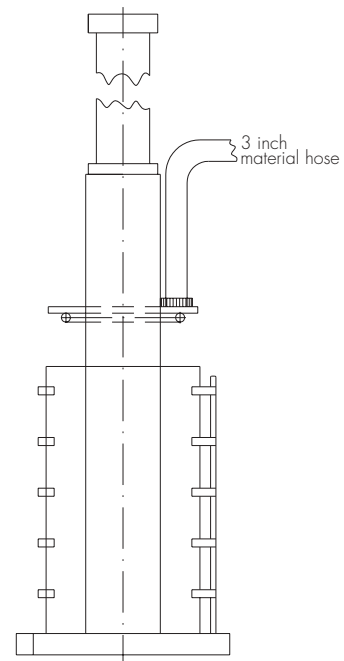

Fischbach



Fischbach KG
Büchlerhausen 18
D-51766 Engelskirchen, Germany

Fischbach Korea Co., Ltd.
Telefon: +82.2.3452.3091
Telefax: +82.2.3452.3095

Fischbach Belgium N.V.
Telefon: +32.3710.9621
Telefax: +32.3710.9631

Fischbach Ibérica, S.A.
Telefon: +34.972.168487
Telefax: +34.972.168324

www.fischbach-fi.com
Telefon: +49.2263.6090
Telefax: +49.2263.60358

Fischbach U.K. Ltd.
Telefon: +44.1928.579320
Telefax: +44.1928.579403

Fischbach USA Inc.
Telefon: +1.270.769.9333
Telefax: +1.270.769.9623

Fischbach GmbH & Co.KG
Telefon: +49.3522.5285 0
Telefax: +49.3522.528511